

A Very Short Tutorial on the Origin of Environmental Sensing in PZT

Radiant Technologies, Inc., Albuquerque, NM USA

radiant@ferrodevices.com

Rev B

November 8, 2008



Radiant Technologies, Inc.

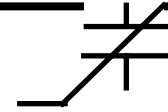

Where do sensor properties come from?

The sensor properties arise directly from the remanent electric dipoles in PZT.

- The dipoles are tied directly to the lattice and their strengths are determined by the lattice spacing.
- Force and temperature change the size of the lattice.
- Changes in the lattice size cause the dipole strength to change and force electrons to flow onto or off of the capacitor plates to keep the net electric field of the capacitor zero!
- Click on this link for a tutorial on the origin of remanent polarization in PZT.

[Link to Hysteresis Tutorial](#)

Radiant Technologies, Inc.

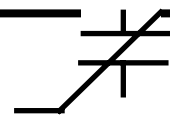

Direct Piezoelectricity

(The generation of charge due to the application of force)

The remanent dipoles exist without an external force applied.

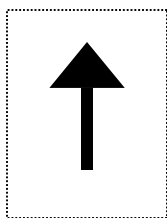

An external force stretching the lattice stretches the dipoles. Charge flows *onto* the capacitor to compensate.

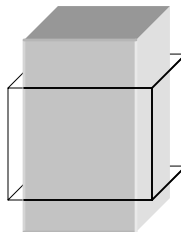
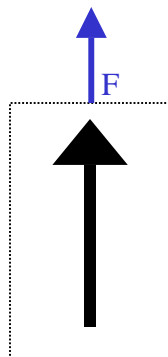

An external force compressing the lattice shrinks the dipole. Charge flows *off of* the capacitor to compensate.

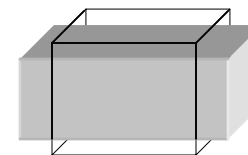
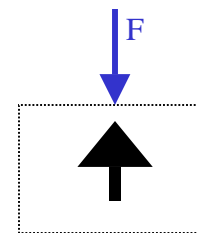

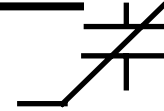

Pyroelectricity

(The generation of charge due to the change in temperature.)

The remanent dipole exists without an external applied field.

A decrease in the temperature makes the lattice shrink more asymmetrically and the dipole strength grows. Charge flows *onto* the capacitor to compensate.

An increase in the temperature makes the lattice expand, allowing more symmetry, and the dipole strength reduces. Charge flows *off of* the capacitor to compensate.

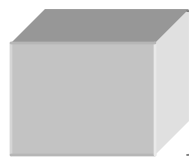
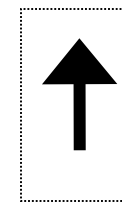
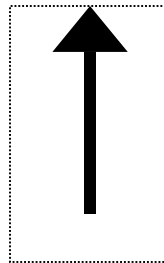
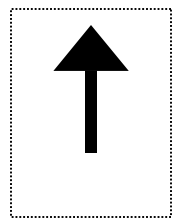

Radiant Technologies, Inc.

The Charge Amp Sensor Circuit

An environmental stimulus, either force or temperature, on a ferroelectric capacitor causes the capacitor to change the amount of charge stored on its plates. An external sensor circuit can keep track of the total charge to leave or enter the capacitor due to the stimulus. The charge integrator circuit below performs this function.

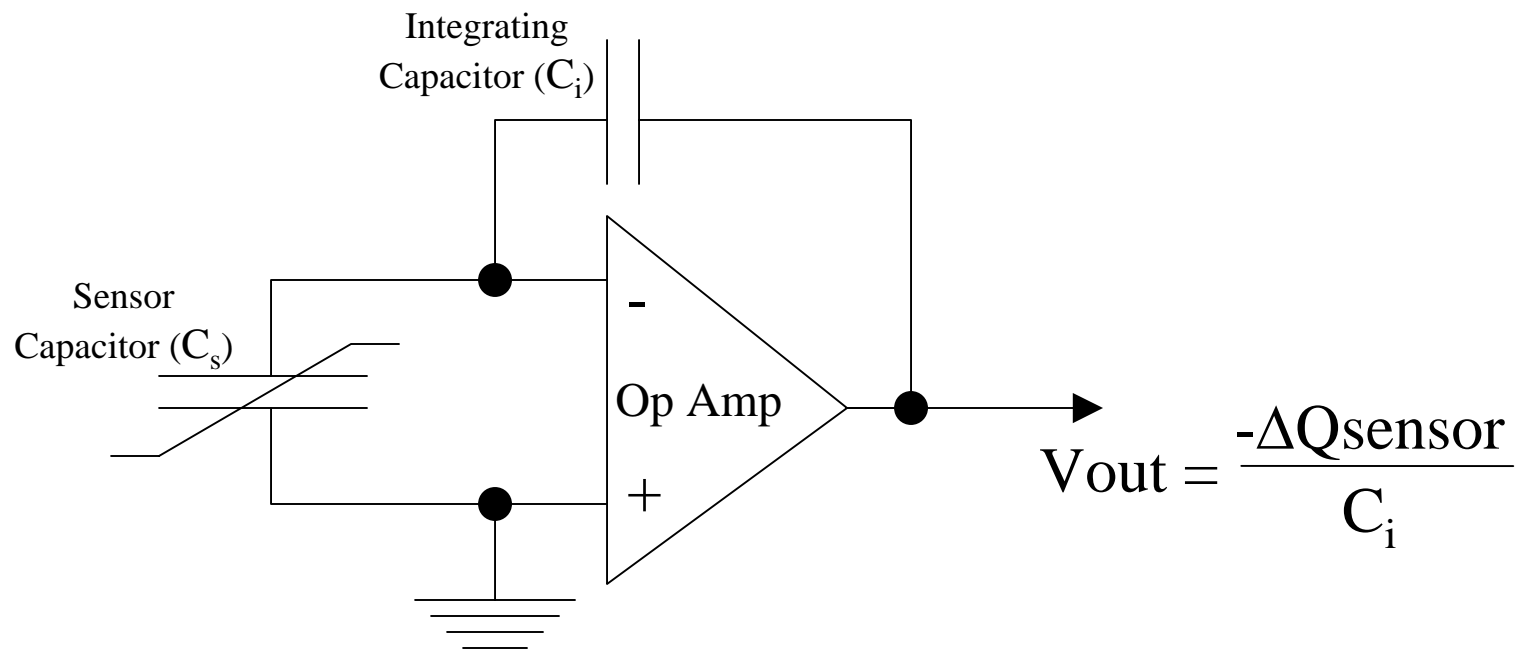

Sensor Circuit Operation

An environmental stimulus forces charge to leave the capacitor. The circuit will act to keep the “-” node of the operational amplifier equal in voltage to the “+” node, i.e. ground. Thus, the output voltage will change to force current to flow through the integrating capacitor C_i from the “-” node so just as much charge leaves the “-” node as enters the node from the sensor capacitor. The voltage on C_i , which is also V_{out} , is the sum of the charge that left or entered the sensor capacitor since the measurement began. The “-” node always stays at zero volts.

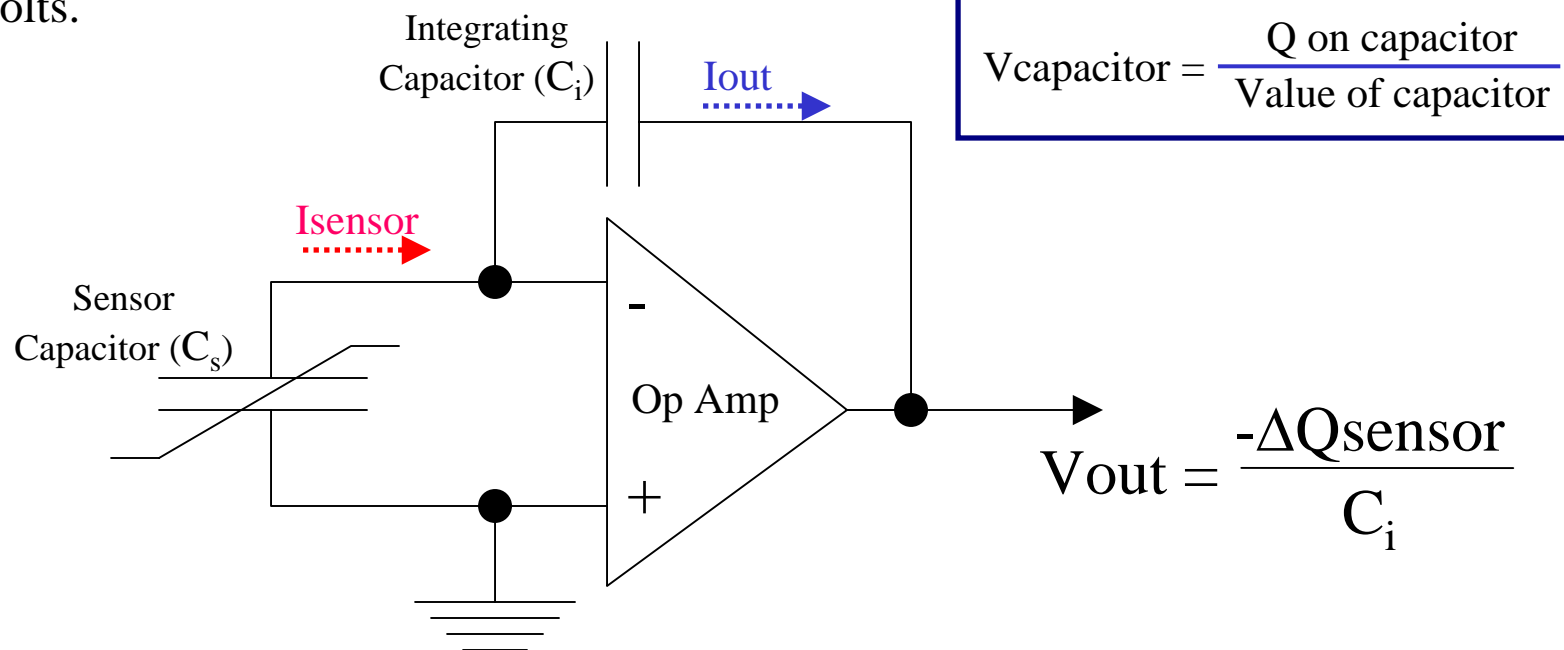

Radiant Technologies, Inc.

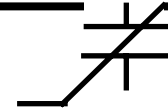

Conclusion: Sensors!

Force (piezoelectricity) and temperature (pyroelectricity) sensing arise directly from the remanent polarization of ferroelectric capacitors. The capacitors are exquisitely sensitive and rugged. Simple circuits may be used to detect changes in the capacitors originating from environmental environment changes around the capacitor.